

Technical Data Sheet

SONOFLOW IL.52/3 V2.0

Ultrasonic Inline Flow Sensor
for Non-Invasive Flow Measurement



(Sensors partly labeled differently, details to labeling in 'Technical drawing')

The compact inline sensor SONOFLOW IL.52/3 V2.0 serves to precisely measure low volume flow rates of liquids. Designed as a built-in component for machines and equipment, the sensor can easily be mechanically installed and electrically integrated into the control system.

Due to the current, frequency and switching output, a wide range of measurement and dosing applications can be supported. The RS-485 interface (SONOTEC protocol; Modbus® via software settings) allows bus operation of up to 12 sensors. Specifically designed for the use in areas with rigorous hygiene requirements, the sensor is suitable for circulation cleaning, steam sterilization and depending on the sensor version also for autoclaving.

All sensors are ready for

- Sterilization-in-place (SIP) and
- Clean-in-place (CIP).

For further details (temperatures), please refer to the section 'Conditions of use' (page 3).

General data

Order number	SONOFLOW type	Connector
200 08 0044	IL.52/3 D8 V2.0	Outer Ø 8 mm, inner Ø 4 mm
200 08 0093	IL.52/3 R1/8" V2.0	With male thread R1/8"
200 08 0155	IL.52/3 SCC V2.0	For straight capillary connector with UNF ¼" - 28 thread; outer tube Ø up to 2 mm
200 08 0156	IL.52/3 LQ1 V2.0	SMC LQ1, size 2

Technical data

Parameter	Specifications
Measuring method	Ultrasound, time of flight measurement, bi-directional
Measurable media	Water or other acoustically transparent, low-viscosity liquids (for applications with high-viscosity liquids, e.g. fats / special paints, screening tests must be made) For media resistance please refer to 'Conditions of use' (page 3)
Measuring cycle	Typical 20 ms (minimum 4 ms)
Upper range value	3 000 ml/min
Accuracy for water (at 23° C ± 2 K, 0 bar)	0 ... 30 ml/min: ± 0.3 ml/min 30 ... 3 000 ml/min: ± 1.0 %
Max. pressure drop	0.95 bar at a flow rate of 3 000 ml/min (value dependent on flow rate, with lower readings accordingly reduced)
Calibration	Factory calibrated for water at 23 °C ± 2 K, outlet of the tubes depressurized (0 bar), other calibration on request
Indirect temperature measurement	Integrated sensor at the inlet; Accuracy ±1 °C, with T _{ambient} = 23 °C and Q = 1 l/min
Measuring channel	Ø 3.0 mm
Adaptor for tube connector	Depending on sensor type; please refer to 'Sensor dimensions and technical drawings' (page 8)
Mounting	Fixed installation: 4 × recessed threaded holes M5, depth: 10 mm
Materials	(In contact with fluid) Measuring channel and cell: PEEK; Seals: FFKM Side plates, rating plate, screws (200 08 0044): stainless steel; Electrical connector: PA black; Pins: brass; Cover caps: PE, white (200 08 0xxx) Peek, natural (200 08 0044)
Dimensions (L × W × H)	See 'Sensor dimensions and technical drawings' (page 8)
Weight	Approx. 370 g
Maintenance	Maintenance-free
Directives and standards	<ul style="list-style-type: none"> • EMC Directive 2014/30/EU • RoHS Directive 2011/65/EU, exception: III 7cl/ IV 15; RoHS 2015/863 • Acoustic emission: IEC 61157:2007 + A1:2013

Conditions of use

Parameter	Specifications	
Media resistance (for measurable media please refer to 'Technical data' page 2)	Cleaning agents: e.g. caustic soda or 3 % nitric acid	
	Not allowed: Strongly oxidizing media such as sulphuric acid with highly concentrated nitric acid or hydrofluoric acid	
Media temperature	In operating state	0 ... +70 °C
	In switched-off state (for cleaning or sterilization)	T > 70 °C, temporarily +145 °C
▲ Only sensor type SONOFLOW IL.52/3 D8 V2.0 (200 08 0044)	In switched-off state (for cleaning or sterilization)	Autoclavable: Max. 5 cycles of 30 minutes at 121 °C
	Ambient temperature	In operation mode
Storage temperature	-20 ... +70 °C	
Protection class	IP65	
Max. pressure	10 bar	

Sensor interfaces

Interface	Specifications
Current output	(0) 4 ... 20 mA Configurable for flow range Load to GND. The max. load depends on the operating voltage: 12 V → 250 Ω 15 V → 500 Ω 24 V → 1 kΩ 30 V → 1.2 kΩ

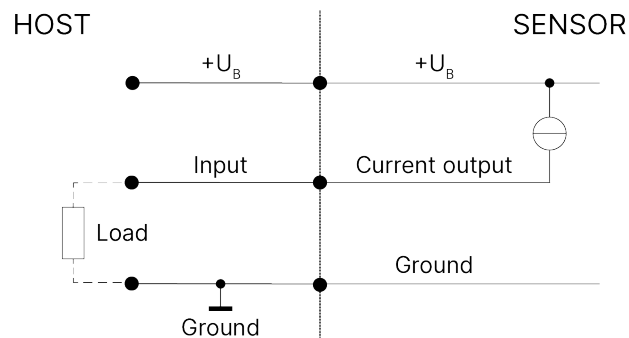

Interface	Specifications
-----------	----------------

Frequency output	0 ... 20 kHz, 5 V digital
-------------------------	---------------------------

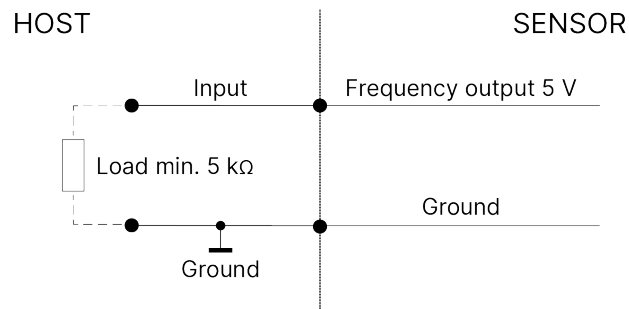

Switching output	Switching characteristics: PNP / NPN / Push-pull 0 ... 30 V max. 100 mA Configurable as: <ul style="list-style-type: none"> • Volume switch (adapting batch process / dosing) • Threshold switch of flow • Pulses of volume (flexible pulse length, max. 20 Hz) • Status information via switch
-------------------------	-----------------------------------------------------------------------------------------------------------------------------------------------------------------------------------------------------------------------------------------------------------------------------------------------------------------------------------------------------

Digital input	Internal pull-up to operating voltage (100 kΩ) Voltage resistant up to 30 V Configurable <ul style="list-style-type: none"> • for zero point adjustment of flow ('Flow zero adjust'; default) • to start dosing (reset the volume counter) (Either separate or simultaneous execution possible). Further option: Sensor restart
----------------------	-------------------------------------------------------------------------------------------------------------------------------------------------------------------------------------------------------------------------------------------------------------------------------------------------------------------------------------------------------------------------------------------

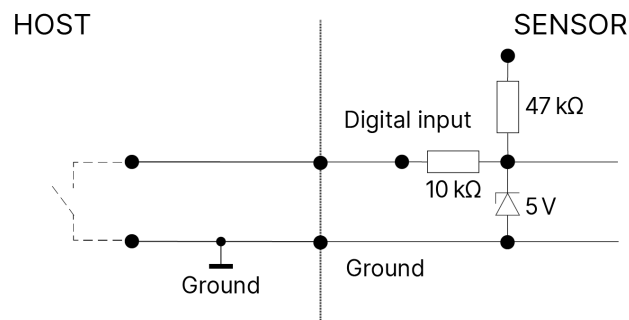

Interface	Specifications
-----------	----------------

RS-485 interface

Available protocols (configurable):

- SONOTEC protocol: Half-duplex operation | 115 200 baud | no parity | 1 stop bit | no handshaking
- Modbus® protocol (via software settings; see accessories)

RS-485 bus operation: max. 12 subscribers | Default address: #01

Description of serial interface on request.

Recommended electrical connection of the RS-485 interface:

NOTE!
If the interface is not used, it does not necessarily has to be connected; the two pins A and B can remain open.

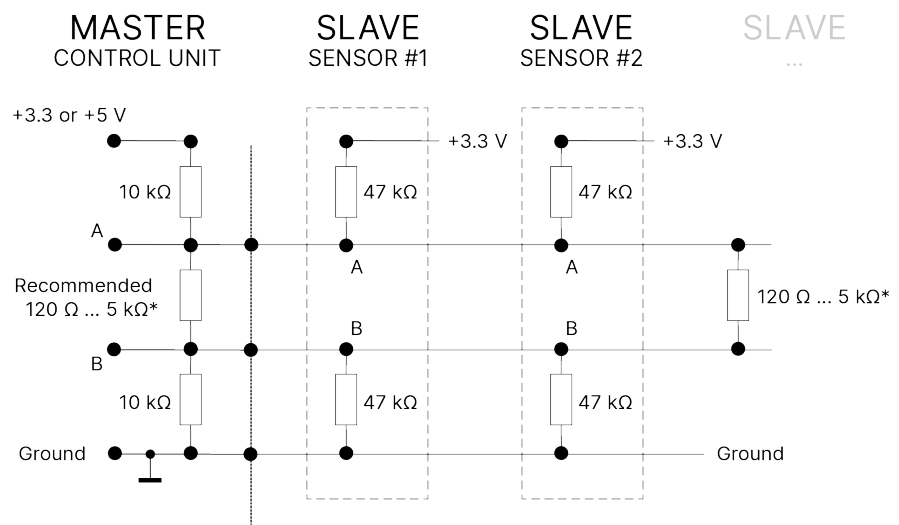

* According to bus standard: depending on number of sensors and cable length

Electrical specifications and connections

Parameter	Specifications
Operating voltage	12 ... 30 VDC, ripple max. 10 %, protection against reverse polarity (external fuse, if required: min. 200 mA)
Current consumption	Maximum 50 mA (with open current, frequency and switching output, depending on supply voltage)
Electrical connection	8 pin M12 connector, DIN EN 61076-2-101:2013

8 pin connector to 8 pole cable

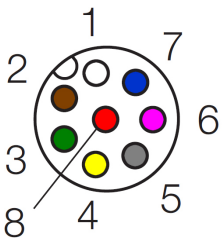
Connection	Pin	Assignment	Color
 <p>Male connector (at the sensor)</p>	1	Ground	White
	2	Operating voltage	Brown
	3	Current output	Green
	4	RS-485 B	Yellow
	5	RS-485 A	Grey
	6	Frequency output	Pink
	7	Switching output: PNP / NPN / Push-Pull	Blue
	8	Digital input	Red

Scope of supply and accessories

Parameter	Specifications
Scope of supply	<ul style="list-style-type: none">• SONOFLOW IL.52/3 V2.0 sensor according to specification• User documentation• Calibration report
Optional accessories	<p>Sensor cable Length: 2 m 8-pole M12 connector</p> <hr/> <p>C³ Software set for setting parameters, recording measurements and updating sensor software, consisting of</p> <ul style="list-style-type: none">• USB Data Converter Type 013 for the connection to a computer• USB cable, type A-B, length 2 m• Cable 2 m, 8-pole M12 connector• Switching power supply 12 V• C3 software package• User documentation <hr/> <p>Monitor SONOFLOW for setting parameters, recording measurements and updating sensor software, consisting of</p> <ul style="list-style-type: none">• USB Data Converter Type 013 for the connection to a computer• USB cable, type A-B, length 2 m• Cable 2 m, 8-pole M12 connector• Switching power supply 12 V• Flow Monitor software package• User documentation <hr/> <p>Remote Display RD.10 including connecting cable for</p> <ul style="list-style-type: none">• Monitoring sensor performance (display e.g. current flow rate, volume or measuring state)• Zero calibration• Manual volume reset <hr/> <p>EtherNet/IP Gateway programmed for SONOTEC</p> <ul style="list-style-type: none">• Serial communication with an EtherNet/IP-based system (e.g. PLC)• Support of up to 12 sensors• Pre-configured parameters and commands (library with Modbus registers for time-saving installation) <hr/> <p>Portable USB Data Converter Type 023 for</p> <ul style="list-style-type: none">• Mobile operation of sensors via a standard USB power socket or power bank• Triggering of functions stored for the digital sensor input ('push button switch')

Sensor dimensions and technical drawings

Design data (STEP files) for integration will be provided upon request. Please feel free to contact us.

SONOFLOW type	Dimensions (L x W x H)	Connector length
IL.52/3 D8 V2.0	148 x 59 x 46 mm	27 mm
IL.52/3 R1/8" V2.0	136 x 59 x 46 mm	22 mm
IL.52/3 SCC V2.0	122 x 59 x 46 mm	15 mm
IL.52/3 LQ1 V2.0	122 x 59 x 46 mm	14 mm

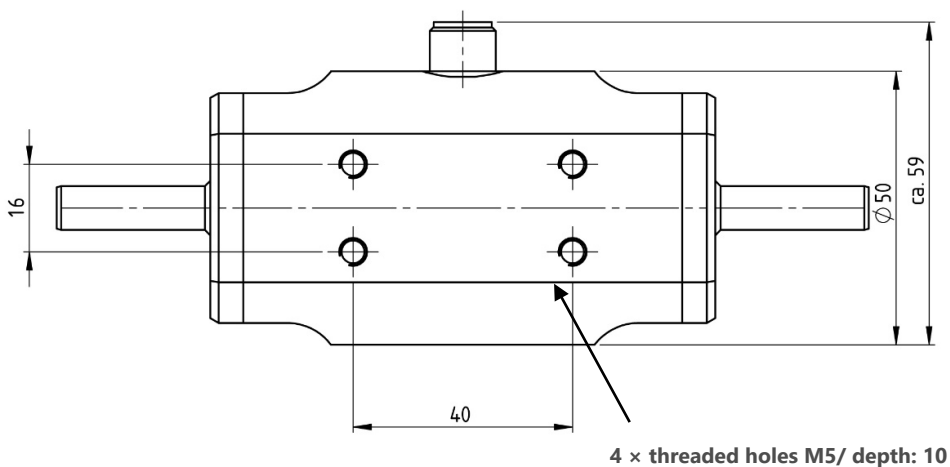
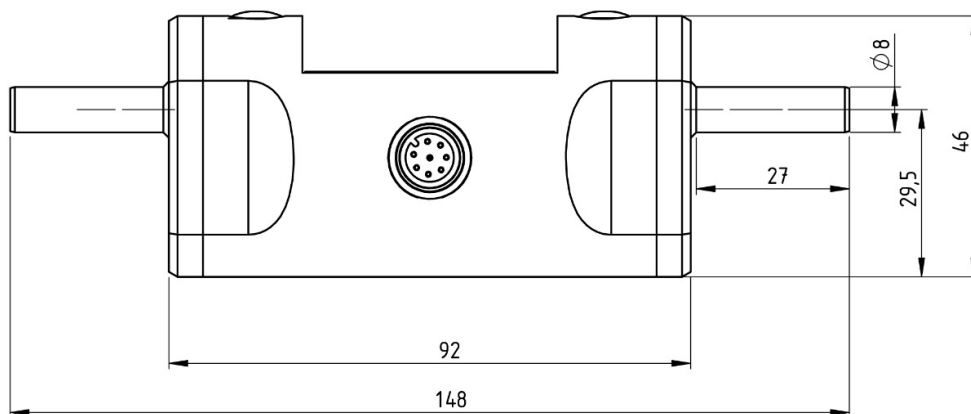

General construction with dimensions (sensor type with D8 connector, 8 mm outer and 4 mm inner diameter)

Connectors

Sensor type: Connector Details

IL.52/3 LQ1 V2.0:
 SMC LQ1, size 2

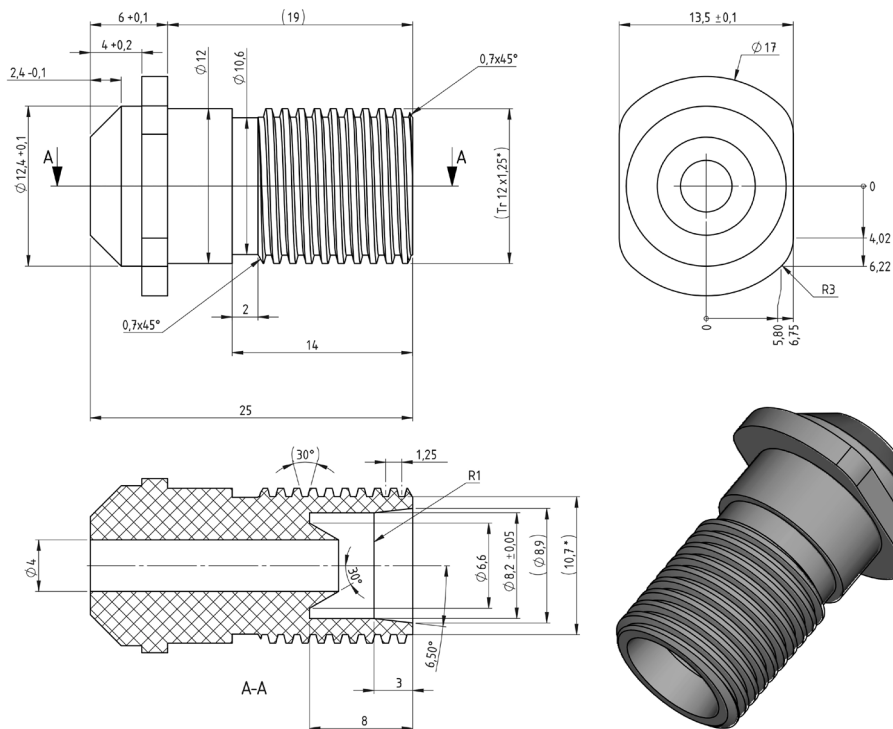

IL.52/3 SCC V2.0:
 For straight capillary
 connector
 with UNF 1/4" - 28 thread)

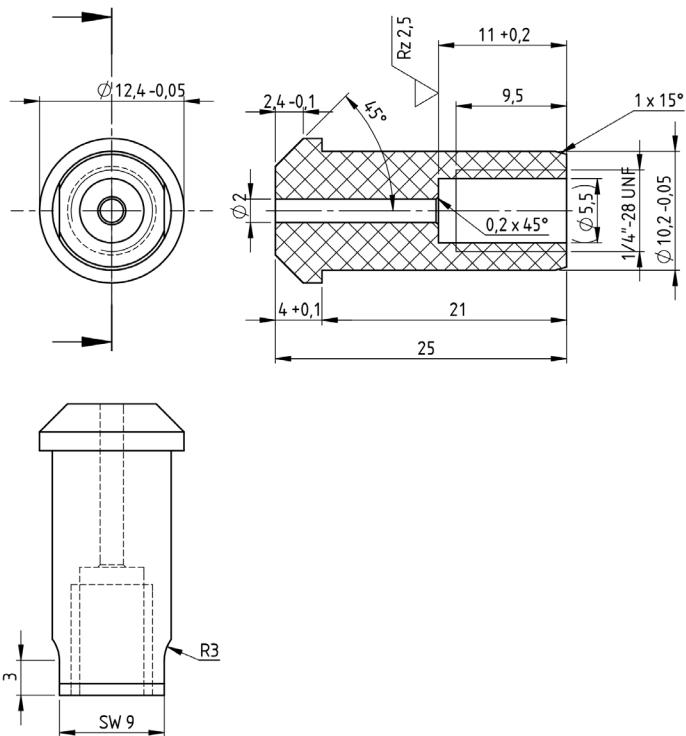

Sensor type: Connector Details

IL.52/3 R1/8" V2.0:
 R1/8" male thread

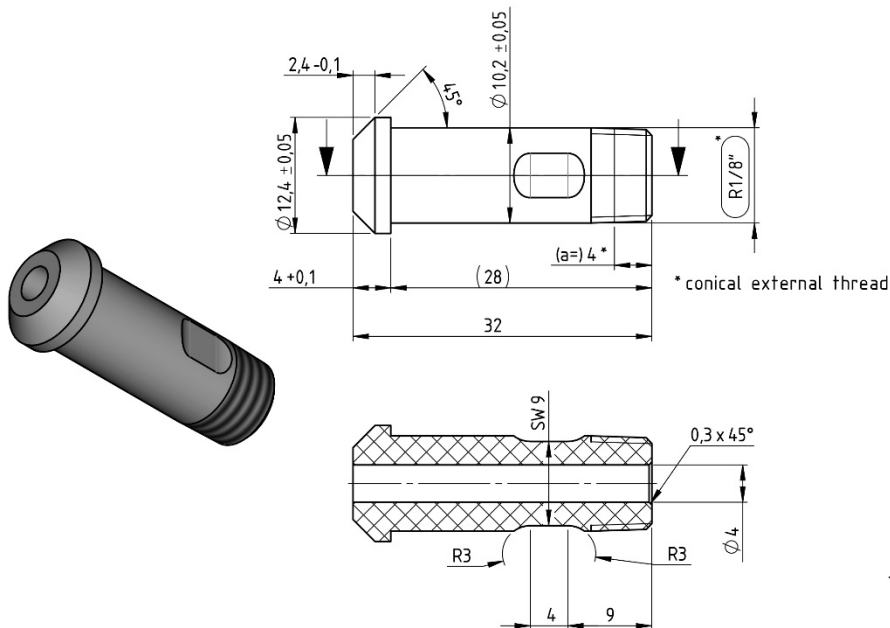

IL.52/3 D8 V2.0:
 Outer Ø 8 mm,
 inner Ø 4 mm

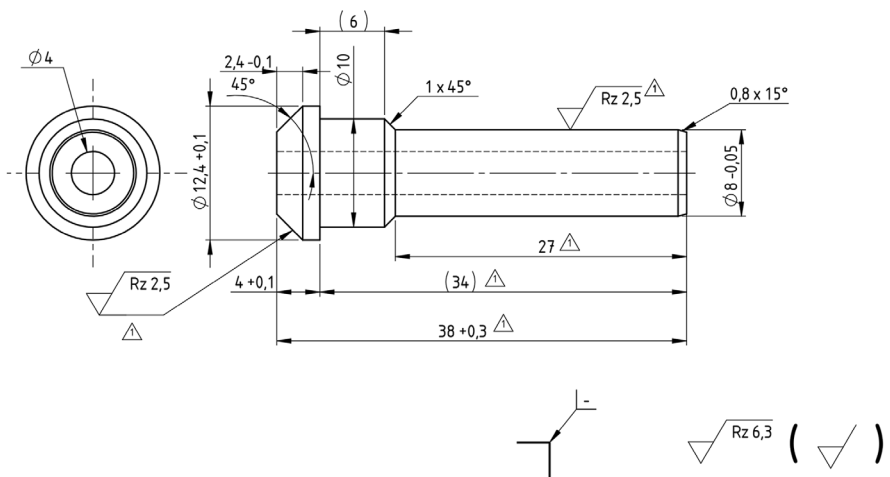

Drawings are not to scale. Dimensions in mm, unless otherwise specified. Information is subject to change without notice. Modbus® is a registered trademark of Schneider Electric and is licensed by the Modbus Organization, Inc. SONOTEC is a registered trademark.

Manufacturer

SONOTEC GmbH
 Thüringer Str. 33
 06112 Halle (Saale)
 Germany

Phone: +49 345 13317-0
sonotec@sonotec.de
www.sonotec.eu

Contact USA

SONOTEC US Inc.
 10 Newton Pl., Ste. 100
 Hauppauge, NY 11788
 USA

Phone: +1 631 4154758
sales@sonotecusa.com
www.sonotecusa.com